

SYSTEM

ESK 165.5 300W

Technical Specifications

Component	-	Two way system
Woofer size	mm (in.)	165 (6.5)
Tweeter diaphragm	mm (in.)	26 (1)
Power handling	W peak	300
	W continuous	100
Impedance	Ω	4
Frequency response	Hz	60 ÷ 23k
Sensitivity	dB SPL	93,5
Woofer magnet size D-d-h	mm (in.)	85 x 32 x 15 (3.35 x 1.26 x 0.5)
Tweeter magnet size D-d-h	mm (in.)	19 x 3 (0.75 x 0.12)
Woofer voice coil Ø	mm (in.)	25 (1)
Tweeter voice coil Ø	mm (in.)	20 (0.8)
Woofer magnet	-	High density flux ferrite
Tweeter magnet	-	Neodymium
Woofer cone	-	Water repellent pressed paper
Tweeter dome	-	Tetolon
Crossover type	-	LP/HP @ 3 kHz - 6/12 dB Oct.
Component adjustment	dB	+2; 0; -2
Woofer weight of one component	kg (lb.)	0,96 (2.12)
Tweeter weight of one component	kg (lb.)	0,03 (0.07)
Crossover weight of one component	kg (lb.)	0,17 (0.37)

Electro-Acoustic Parameters

		Tweeter	Woofer
D	mm	20	134
Xmax	mm	-	3
Re	Ω	3,7	3,1
Fs	Hz	1350	70
Le	mH	0,02	0,18
Vas	l	-	10,4
Mms	g	0,19	13,7
Cms	mm/N	0,07	0,37
BL	T·m	1,5	5
Qts	-	0,9	0,61
Qes	-	2,7	0,76
Qms	-	1,5	3,2
Spl	dB	92	93,5



ET 26.5

1. Tetolon dome, with hemispheric profile and wide roll surround; extremely light weight and properly damped for smooth and extended high frequency response.
2. Acoustic compression chamber; high efficiency and off-axis optimized response.
3. CCAW (Copper Clad Aluminium Wire) ultra light ferrofluid-cooled mobile voice coil.
4. High energy neodymium magnet.
5. Low carbon content plates for maximum magnetic permeability and high heat dissipation.
6. Damping material; controlling acoustic resonances insuring clear, high frequenc tones.

EV 165.5

1. V-cone® for best off-axis response and clear mid-high frequency detail.
2. Water-repellent treated paper cone; butyl rubber surround.
3. Pure copper voice coil, wound on aluminium former, for exceptional thermal and mechanical capacity.
4. Large motor assembly for excellent control of voice coil.
5. Low carbon content plates for maximum magnetic permeability and high heat dissipation.
6. Rubber magnet cover provides damping to the basket and motor structure and protects from abrasions and damages.
7. DIN size basket coated with scratch-proof, corrosive-resistant material.
8. Tin-plated, high current terminals.
9. Silver-plated lead wires, for maximum reliability and conductivity.
10. Epoxy glue for basket and motor system provides perfect coupling.
11. Curve memory Nomex spider for consistent, reliable performance.

- Tweeter mounting accessories and woofer grille included

SYSTEM energy

ESK 165.5 300W

A	165 mm	6.5 in.
B	142 mm	5.6 in.
C	70 mm	2.83 in.
D	64 mm	2.56 in.

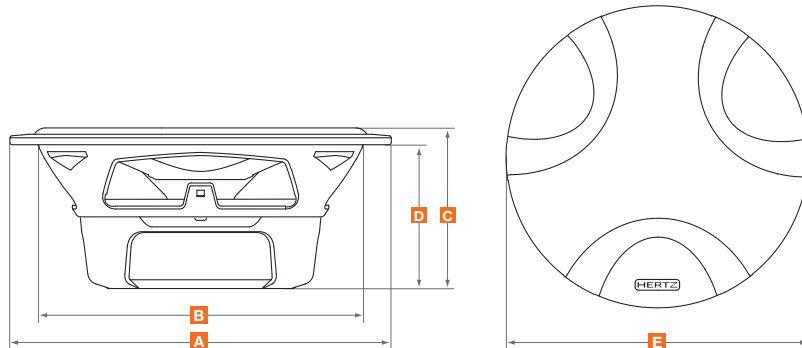

E	184 mm	7.25 in.
F	25 mm	0.98 in.

G	102,5 mm	4.03 in.
H	82 mm	3.23 in.
I	34 mm	1.34 in.

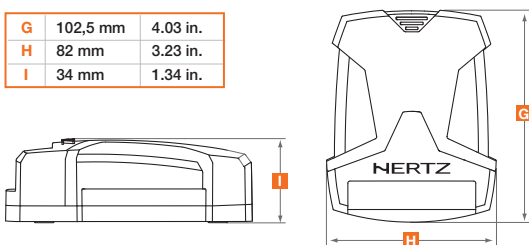

A	44 mm	1.7 in.
B	38,5 mm	1.5 in.
C	20 mm	0.78 in.
D	8,5 mm	0.33 in.

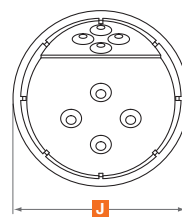
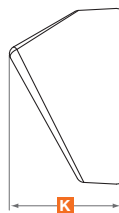
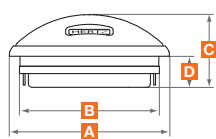

K	28,3 mm	1.11 in.
J	44,3 mm	1.75 in.
R	48 mm	1.89 in.
S	10 mm	0.4 in.
T	10 mm	0.4 in.

